

Technical Data

NTH / NTT Series, Type H

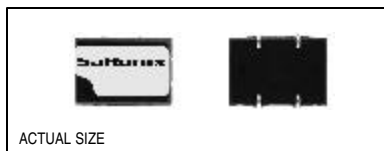

Description

A crystal controlled, 3.3 or 5 volt, low current oscillator designed to drive low power, high performance microprocessors. The plastic-molded surface mountable package is ideal for today's automated assembly environments. J-leads are compatible with EIA standard footprints. The HCMOS device is capable of driving both CMOS and TTL loads.

Applications & Features

- Footprint compatible and direct replacement for SG615 series
- Frequency range from 1 to 70 MHz
- 3.3V and 5V versions
- Tri-State output standard
- Low voltage CMOS, HCMOS and TTL compatible
- Ideally suited for use with contemporary MPUs and custom ASICs
- Perfect for PCs, laptop, portable applications; disc drives - anywhere small size, low power and surface mountability are a priority
- Matches EIA standard SO-J-20 footprint
- Compact, plastic-molded, surface mountable package
- Available in embossed tape & reel

Frequency Range:	1 MHz to 70 MHz		
Frequency Stability:	±50 or ±100 ppm over all conditions: calibration tolerance, operating temperature, input voltage change, load change, aging, shock and vibration.		
Temperature Range:	Operating: 0°C to +70°C or -40°C to +85°C Storage: -55°C to +125°C		
Supply Voltage:	Recommended Operating: 5V ±10% or 3.3V ±10% (HCMOS only)		
Supply Current:	5V, 10TTL/30pF	5V, 50pF	@ 3.3V
1 MHz to 26 MHz:	15mA max	35mA max	15mA max
26+ MHz to 50 MHz:	30mA max	45mA max	20mA max
50+ MHz to 70 MHz:	45mA max		25mA max

Output Drive:

HCMOS

Symmetry:	40/60% or 45/55% max @ 50% V _{DD} , See Part Numbering Guide
Rise & Fall Times:	8ns max 20% to 80% V _{DD} @ 5V 5ns max 20% to 80% V _{DD} @ 3.3V
Logic 0:	10% V _{DD} max or 0.4V max @ 3.3V
Logic 1:	90% V _{DD} min or V _{DD} -0.4 min @ 3.3V
Load:	50 pF max to 50 MHz, 30 pF 50+ to 70 MHz, 15 pF @ 3.3V operation
Jitter:	8ps max RMS period jitter, 1ps max 1σ cycle-to-cycle jitter

TTL (5V)

Symmetry:	40/60% or 45/55% max @ 1.5V level, See Part Numbering Guide
Rise & Fall Times:	8ns max 0.5 to 2.5V
Logic 0:	0.5V max
Logic 1:	2.5V min
Load:	10 TTL to 50 MHz, 5 TTL 50+ to 70 MHz
Jitter:	8ps max RMS period jitter, 1ps max 1σ cycle-to-cycle jitter

Mechanical:

Shock:	MIL-STD-883, Method 2002, Condition B
Solderability:	MIL-STD-883, Method 2003
Terminal Strength:	MIL-STD-883, Method 2004, Condition B2
Vibration:	MIL-STD-883, Method 2007, Condition A
Solvent Resistance:	MIL-STD-202, Method 215
Resistance to Soldering Heat:	MIL-STD-202, Method 210, Condition I or J

Environmental:

Thermal Shock:	MIL-STD-883, Method 1011, Condition A
Moisture Resistance:	MIL-STD-883, Method 1004

Solder Reflow Guide

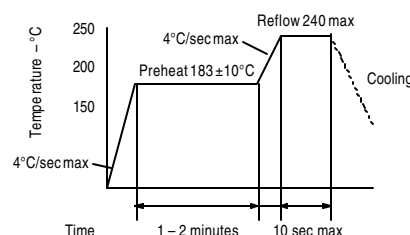

Output Waveform

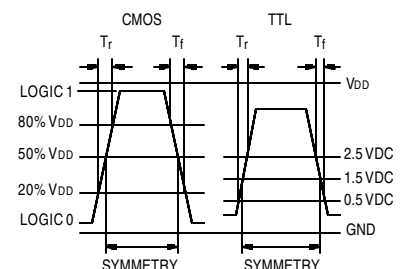

Technical Data

NTH / NTT Series, Type H

Tri-State Logic Table

Pin 1 Input	Pin 3 Output
Logic 1 or NC	Oscillation
Logic 0 or GND	High Impedance

Required Input Levels on Pin 1:

- Logic 1 = 2.0V min
- Logic 0 = 0.8V max or 0.2V max @ 3.3V

Package Details, Type H

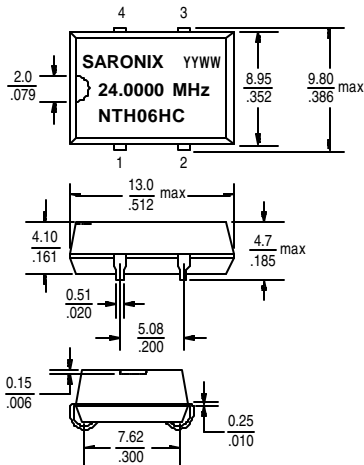

Pin Function:

- Pin 1: Tri-State Control
- Pin 2: GND
- Pin 3: Output
- Pin 4: +5 VDC

Recommended Land Pattern

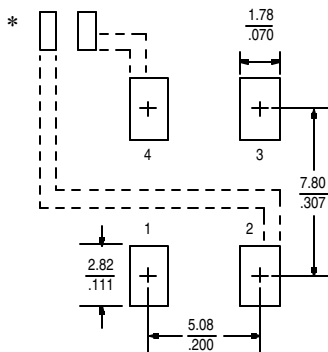

*External high frequency power supply

Scale: None (Dimensions in mm/inches)

Part Numbering Guide

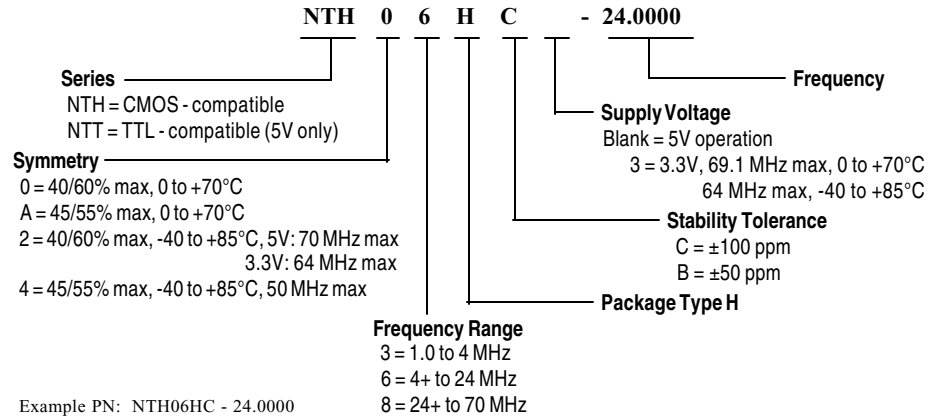

Test Circuits

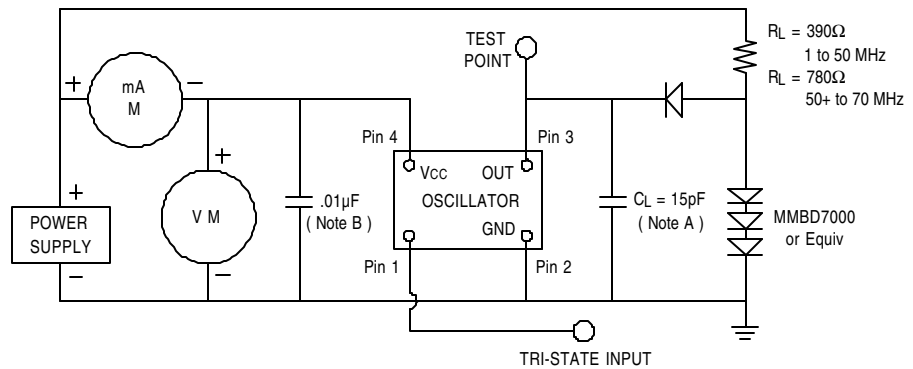

- NOTE: A. C_L includes probe and fixture capacitance.
- NOTE: B. An external $.01\mu\text{F}$ bypass capacitor close to package ground and VCC pin is required

FIGURE 1 - TTL TEST CIRCUIT, 5V OPERATION

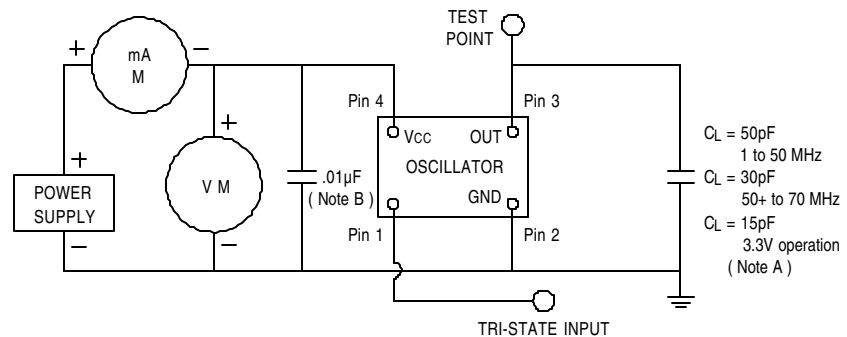

- NOTE: A. C_L includes probe and fixture capacitance.
- NOTE: B. An external $.01\mu\text{F}$ bypass capacitor close to package ground and VCC pin is required

FIGURE 2 - HCMOS TEST CIRCUIT, 3.3V OR 5V OPERATION

All specifications are subject to change without notice.