

### Technical Data

### STA / STT Series



#### Description

A crystal controlled, low-current oscillator providing precise rise and fall times to drive TTL loads and TTL microprocessors like the Intel 486 and Pentium, Motorola 68040, National 32532, AMD 29000, LSI 64901 and MIPS R3000/R4000. The tri-state function enables the output to go high impedance. Available in either a 14 or an 8 pin DIP compatible, resistance welded, all metal case. Pin 7 (or Pin 4) is grounded to case to reduce EMI.

#### Applications & Features

- Ideally suited for clock generation requirements of today's CISC and RISC based systems
- Very broad frequency range 0.25 MHz to 135 MHz
- High Drive HCMOS, ACMOS or TTL capability
- Tri-State output
- Precise Rise/Fall Times
- Reduced EMI circuitry
- Short circuit protected output
- Also available in plastic, surface mount STA/STT Series, see separate data sheet

\*R/F times are standard with given frequency ranges, non-standard R/F times available on some models. Consult factory.

\*\*TTL: to 80 MHz max

<b>Frequency Range:</b>	0.25 MHz to 135 MHz
<b>Frequency Stability:</b>	±50 or ±100 ppm over all conditions: calibration tolerance, operating temperature, rated input voltage change, load change, aging*, shock and vibration * 1 year @ +40°C
<b>Temperature Range:</b>	Operating: 0 to +70°C or -40 to +85°C available Storage: -55 to +125°C
<b>Supply Voltage:</b>	Recommended Operating: +5V ±10% or 3.3V ±10% (STA only)
<b>Supply Current:</b>	50mA typ, 70mA max @ 5V or 30mA typ, 45mA max @ 3.3V
<b>Output Drive:</b>	<u>ACMOS / TTL</u> Symmetry: 40/60% max @ 50% VDD or 1.5V level 45/55% max @ 50% VDD (1.5V level available to 80 MHz) Rise & Fall Times: See Part Numbering Guide Logic 0: 10% VDD or 0.5V max Logic 1: 90% VDD or 2.5Vmin Load: 50Ω ACMOS, 95Ω ACMOS @ 3.3V, 50mA sink & source @ TTL Jitter: 8ps max RMS period jitter, 1ps max 1σ cycle-to-cycle jitter
<b>Mechanical:</b>	Shock: MIL-STD-883, Method 2002, Condition B Solderability: MIL-STD-883, Method 2003 Terminal Strength: MIL-STD-202, Method 211, Conditions A & C Vibration: MIL-STD-883, Method 2007, Condition A Solvent Resistance: MIL-STD-202, Method 215 Resistance to Soldering Heat: MIL-STD-202, Method 210, Condition A, B or C
<b>Environmental:</b>	Gross Leak Test: MIL-STD-883, Method 1014, Condition C Fine Leak Test: MIL-STD-883, Method 1014, Condition A2 Thermal Shock: MIL-STD-883, Method 1011, Conditions A Moisture Resistance: MIL-STD-883, Method 1004

#### Part Numbering Guide

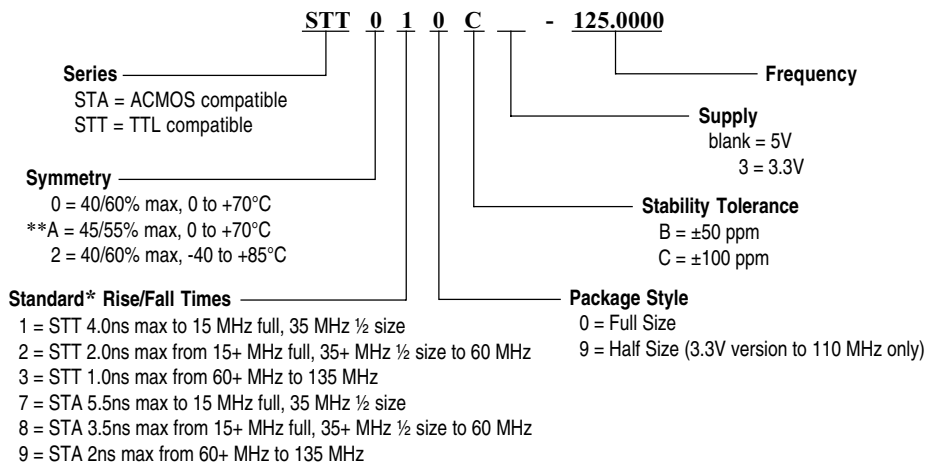

Example PN: STT030C - 100.0000

# SaRonix

## Crystal Clock Oscillator

3.3 & 5V, HCMOS, AC MOS, TTL

### Technical Data

STA / STT Series

#### Package Details

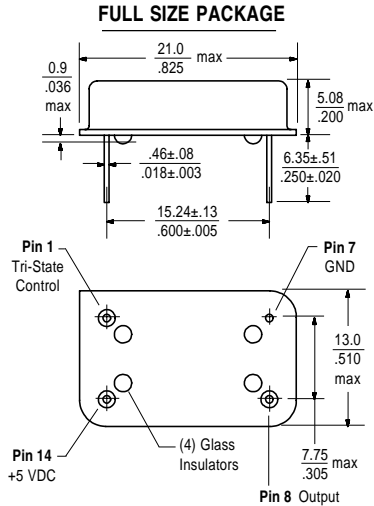

**Marking Format \*\***  
Includes Date Code, Frequency & Model

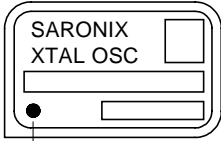

#### HALF SIZE PACKAGE

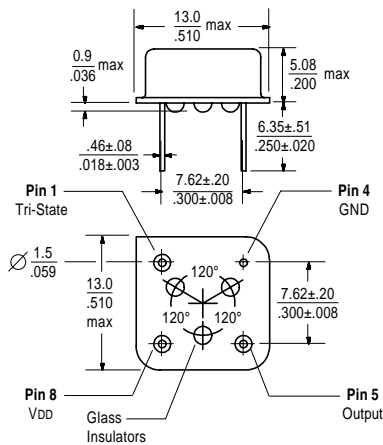

**Marking Format \*\***  
Includes Date Code, Frequency & Model



\*\* Exact location of items may vary

Scale: None (Dimensions in mm / inches)

#### Output Waveform

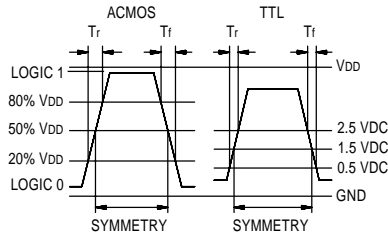

#### Tri-State Logic Table

Pin 1 Input	Output Standard Logic
Logic 1 or NC	Oscillation
Logic 0 or GND	High Impedance

Required Input Levels on Pin 1:  
Logic 1 = 2.0V min  
Logic 0 = 0.8V max

#### Test Circuit

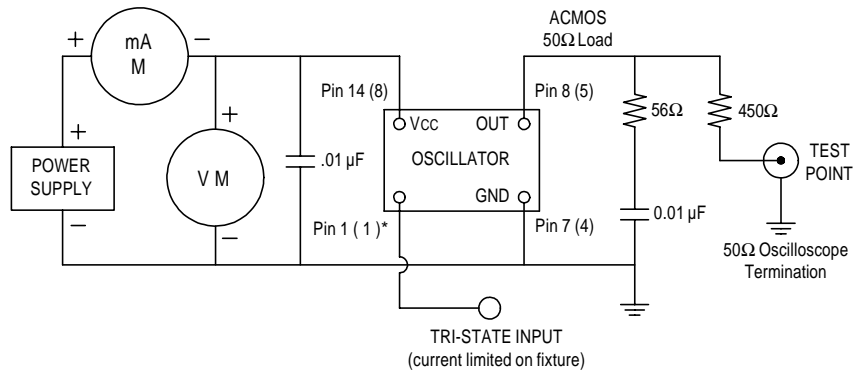

\* ( ) Indicates pin numbers for half-size package

**50Ω AC MOS TEST CIRCUIT (5V operation)**

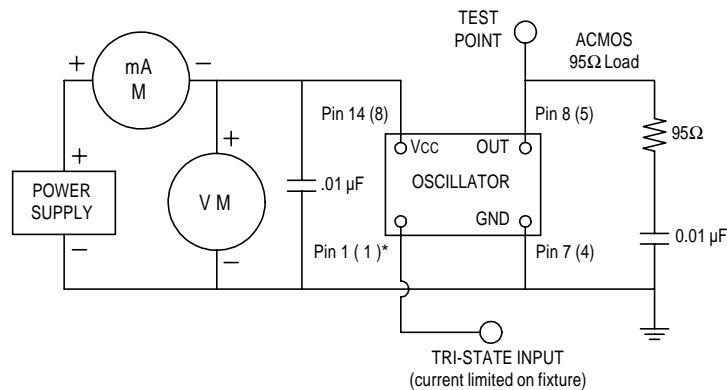

\* ( ) Indicates pin numbers for half-size package

**95Ω AC MOS TEST CIRCUIT (3.3V operation)**

All specifications are subject to change without notice.

DS-108 REV H

3.28